

**INSTALLATION AND MAINTENANCE INSTRUCTION
DIRECT ACTING SOLENOID VALVE (2/2 & 3/2 WAY) D & T SERIES
(2/2 – NORMALLY OPEN & NORMALLY CLOSE)**

Uflow Automation

Ankur Industrial Complex, Survey No: 275/276, Plot No: 31,

Nr. Intol Cast Pvt. Ltd. Shapar (Veraval) 360 024.

Dist: Rajkot Gujarat (INDIA).

For Maintenance & Service: +91 75 75 86 86 62

Email: info@uflowvalve.com | Website: www.uflowvalve.com

Contents

- 01) Valve instruction 01
- 02) Temperature Limitations 01
- 03) Positioning 01
- 04) Storage of valves 01
- 05) Operation 01
- 06) Installation 01
- 07) Basic safety instruction 02
- 08) Maintenance 02
 - 8.1) Preventive maintenance 02
 - 8.2) Cleaning 02
 - 8.3) Valve assembly , disassembly & routine testing of valve 03
 - 8.4) Standards 04
- 09) Trouble shooting guide & awareness 04

01) Valve Instruction

- › Direct acting piston operated (UMD type) valves are 2-way & 3-way normally closed solenoid valves designed for low and high pressure service. Valves are made of from stainless steel 304 / 316, brass, Aluminium.
- › Direct acting piston operated (UMD type) valves they are also provided with a whether proof and flameproof coil.

02) Temperature Limitations

- › **Ambient Temperature:** - 20 °C to 40 °C
- › **Sealing Material Temperature:** -30 °C to 90 °C Nitrile (NBR) , -10°C to 140°C (EPDM) , -10°C to 160°C Viton (FKM)/Special Viton,
- › **Suitable Media:** Air, Water, Chemical, Gases, Oil, Diesel, Kerosene, LPG, Steam (Media Temperature as per sealing material)

03) Positioning

- › Valve is designed to perform properly when mounted in any position. However, for optimum life and performance, the solenoid should be mounted vertical to reduce the possibility of foreign matter accumulating in the solenoid base sub-assembly area.

04) Storage of valves

- › On receipt, check the valve to ensure that it is in fully assembled condition.
- › Valve should be stored above the ground level or rack.
- › Do not apply tar, paint, grease or any other material inside the valve or on plunger as this could impair performance of the valve.
- › Please pay attention to following symbols.

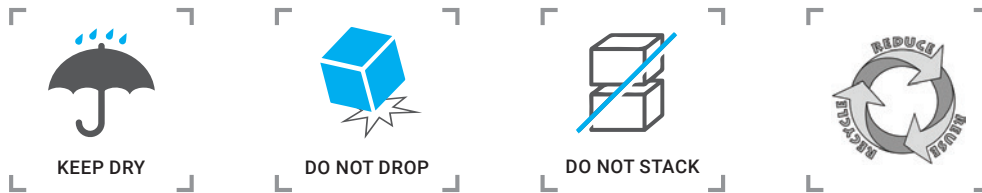

- › Do not expose the coil & valve in below critical environmental conditions.



05) Operation

- › Direct acting piston operated (UMD type) valves have an open and close operation, closing in de-energized position and opening in energized position.(Reverse process in 3 way valve).
- › Piston rubber button provides sealing with body orifice and it is held on position by spring connection which is mounting with piston.
- › Valve open and closed position working by piston movement in plunger.
- › Seat testing/ Body test carried out with hydro and pneumatic test.

06) Installation

- › If required any compound or chemical apply on male thread only (On pipe). Avoid pipe strain by properly supporting and aligning piping. When tightening the pipe, do not use valve or solenoid as a lever. Locate wrenches applied to valve body or piping as close as possible to connection point.
- › To protect the solenoid valve, install a strainer or filter suitable for the service involved in the inlet side as close to the valve as possible. Clean periodically depending on service conditions
- › Check identity sticker for correct valve number, pressure, voltage. Never apply incompatible fluids or exceed pressure rating of the valve.

- › Must check coil voltage on coil sticker before connect with power supply.



USE TEFLON TAPE FOR PROPER JOINT WITH VALVE.
(REFER FIG. FOR PROPER USE OF TEFLON TAPE)

07) Basic Safety instruction

- › These safety instructions do not make allowance for any ,
- › Contingencies and events which may arise during the installation, operation and maintenance of the devices.
- › Local safety regulations; the operator is responsible for observing these regulations, also with reference to the installation personnel

Danger – High Pressure

- › Before loosening the lines and valves, turn off the pressure lines.

Risk of electric shock!

- › Before reaching into the device or the equipment, switch off the power supply end secure to prevent reactivation!
- › Observe applicable accident prevention and safety regulation for electric equipment.

Risk of burns/risk of fire if used continuously through hot device surface!

- › Keep the device away from highly flammable substances and media and do not touch with bare hands.

General Hazardous situations.

- › The system cannot be activated unintentionally.
- › Installation and repair work may be carried out by authorized technician only and with appropriate tools.
- › After interruption in the power supply or pneumatic supply, ensure that the process restarted in a defined or controlled manner.
- › The devised may be operated only when In perfect condition and in consideration of the operating instructions.
- › The general rules of technology apply to application planning and operation of the device.

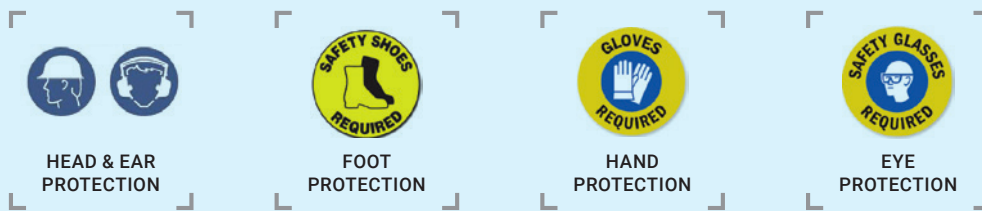

08) Maintenance

WARNING: if found any guilty in valve, turn off electrical power, depressurize valve, and vent fluid to a safe area before servicing the valve.

8.1) Preventive maintenance

- › Keep the medium flowing through the valve as free from dirt and foreign material as possible.
- › Valve should be operated/services at least once a month as per your application or usage.

8.2) Cleaning

- › Valve should be serviced as per application and usage. If not done excessive noise or leakage will be observed. Clean strainer or filter when cleaning the valve.

8.3) Valve Assembly , Disassembly & testing of valve

> Disassembly of valve

- Remove coil from plunger.
- Remove plunger from body, use spanner slot for loose plunger threading.
- All parts are now accessible for cleaning or replacement. If parts are worn or damaged, inform to UFLOWAUTOMATION.

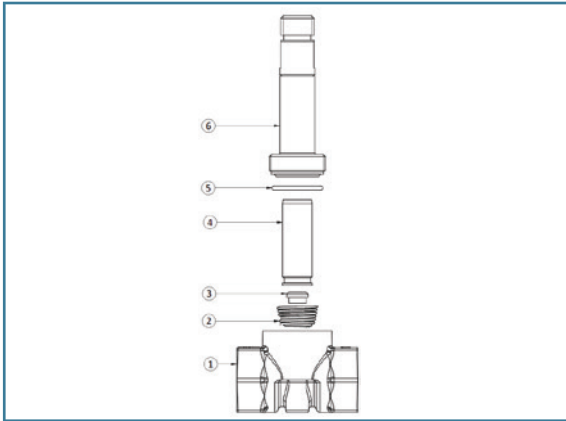

BILL OF MATERIAL – 2/2 WAY VALVE NORMALLY CLOSE			
SR. NO	PART NAME	MATERIAL	Qty.
1	BODY	BRASS, ALU., SS	1
2	SPRING	SS304 & SS316	1
3	RUBBER BUTTON	NBR / EPDM / SILICONE / VITON / SPL.VITON	1
4	PISTON	SS 430 F	1
5	O RING	NBR / EPDM / SILICONE / VITON / SPL.VITON	1
6	PLUNGER ASSEMBLY	-	1

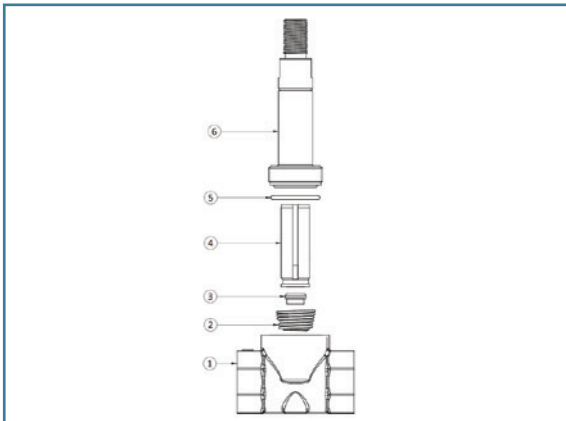

BILL OF MATERIAL – 3/2 WAY VALVE NORMALLY CLOSE			
SR. NO	PART NAME	MATERIAL	Qty.
1	BODY	BRASS, ALU., SS	1
2	SPRING	SS304 & SS316	1
3	RUBBER BUTTON	NBR / EPDM / SILICONE / VITON / SPL.VITON	1
4	PISTON	SS 430 F	1
5	O RING	NBR / EPDM / SILICONE / VITON / SPL.VITON	1
6	PLUNGER ASSEMBLY	-	1

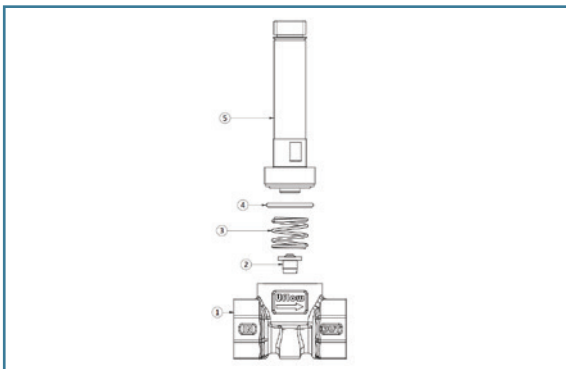

BILL OF MATERIAL – 2/2 WAY VALVE- NORMALLY OPEN			
SR. NO	PART NAME	MATERIAL	Qty.
1	BODY	SS / BRASS / ALUMINUM	1
2	ORIFICE	SS / BRASS	1
3	SPRING	SS304 / SS316	1
4	O RING	NBR / EPDM / SILICONE / VITON / SPL. VITON	1
5	PLUNGER ASSEMBLY	-	1

› **Reassembly of valve**

- Parts must be clean properly.
- Install body diaphragm into valve body.
- Install cover assembly with diaphragm spring into valve body.
- Assemble cover with body by fasteners.
- If removed, re-assemble piston, piston spring and plunger
- Install plunger with piston assembly.
- Recheck line pressure and electrical power supply to valve.
- After reassemble is completed, operate the valve a few times to be sure of proper operation.

› **Routine testing of valve**

- Body seat and body seal leakage test
- Pick up and drop down test.
- Material hardness test.
- Coating thickness test (Powder Coated and anodized parts).
- Impact test for flame proof coil enclosure.
- Valve and coil life cycle test.

8.4) Standards

- › EN / ISO 80079-36 : 2016
- › EN / ISO 80079-37 : 2016

09) Trouble Shooting Guide & Awareness

TROUBLESHOOTING GUIDE FOR SOLENOID VALVES	
PROBLEM	PROCEDURE
Valve fails to operate	Check electrical supply with voltmeter. Voltage must agree with nameplate rating
	Check coil with ohmmeter for shorted or opened coil. If open or short replace it.
	Make sure that pressure & electric parameter complies with nameplate rating.
Valve is sluggish or inoperative - electrical supply and pressure check out.	Disassemble valve; clean out foreign material.
	The piston must be free in plunger without binding. Piston spring must be assembled properly without elongate or cut-out length. If damage found then replace it.
	Check the diaphragm or diaphragm pad for tears, bulged and/or clogged or obstructed bleed hole or orifice. Damage diaphragm must be replace it.
	Check all springs. If broken, replace
External leakage at joint between body and plunger	Check that the cover screws are torqued to specifications. If leakage persists, replacement of diaphragm assembly may be required and/or bodies or covers with damaged sealing surfaces may have to be replaced. Flanges are tight as per specification.